

Demo: Organic Solar Cell-equipped Energy Harvesting Active Networked Tag (EnHANT) Prototypes

Gerald Stanje¹ Paul Miller¹ Jianxun Zhu¹ Alexander Smith¹
gstanje@edu.uni-klu.ac.at psm2130@columbia.edu jz2382@columbia.edu ajs2216@columbia.edu

Olivia Winn¹ Robert Margolies¹ Maria Gorlatova¹ John Sarik¹
oaw2102@columbia.edu rsm2156@columbia.edu mag2206@columbia.edu jcs2160@columbia.edu

Marcin Szczodrak² Baradwaj Vignanam¹ Luca Carloni² Peter Kinget¹
msz@cs.columbia.edu bv2152@columbia.edu luca@cs.columbia.edu kinget@ee.columbia.edu

Ioannis Kymissis¹ Gil Zussman¹
johnkym@ee.columbia.edu gil@ee.columbia.edu

Electrical Engineering¹ and Computer Science²
Columbia University
New York, NY, 10027, USA

Abstract

Energy Harvesting Active Networked Tags (EnHANTs) will be a new class of devices in the domain between RFIDs and sensor networks. Small, flexible, and energetically self-reliant, EnHANTs will be attached to objects that are traditionally not networked, such as books, furniture, toys, produce, and clothing. More information about the EnHANTs project is available at <http://enhants.ee.columbia.edu>. In this demo we present a small *network of EnHANT prototypes*. The current EnHANT prototypes are integrated with novel *custom in-house-developed* energy harvesting and communications hardware, namely *organic solar cells* and *ultra-wide-band impulse radio (UWB-IR) transceivers*. The demo showcases prototypes communicating using the novel UWB-IR transceivers and adapting their communications and networking parameters to the available environmental energy harvested by the organic solar cells.

Categories and Subject Descriptors

C.2.1 [Computer-Communication Networks]: Network Architecture and Design — *Wireless Communication*

General Terms

Design, Experimentation, Performance

Keywords

Energy harvesting, organic solar cells, ultra-low-power communications, ultra-wideband impulse radio, energy adaptive networking

1 System Description

Energy Harvesting Active Networked Tags (EnHANTs) will be *ultra-low-power*, small, lightweight, *flexible* tags that harvest environmental energy and form pervasive multihop networks. EnHANTs will enable the *Internet of Things* by providing the infrastructure for tracking applications. Recent

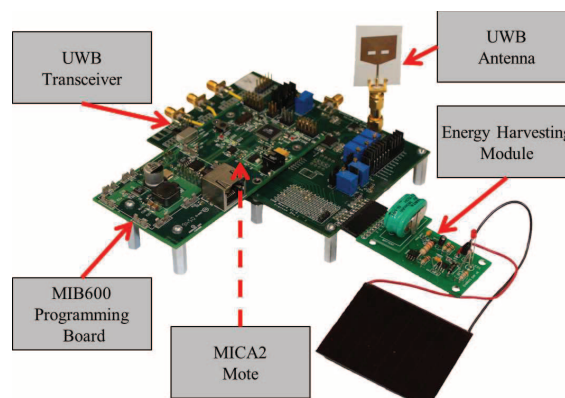

Figure 1. An EnHANT prototype.

advances in ultra-low-power UWB-IR wireless communications (e.g., [1]), and in organic energy harvesting techniques (e.g., [7]) will enable the realization of EnHANTs in the near future [3]. Over the past two years, we have presented previous stages of EnHANTs prototype development [4, 5, 10] using commercial off-the-shelf components. In this demo, all prototype components except the MICA2 motes are *custom designed and developed* for this project. The prototype testbed we present showcases wireless communications, energy harvesting, and energy-adaptive networking functionalities enabling the future EnHANTs.

An EnHANT prototype is shown in Fig. 1. Current prototypes rely on the microprocessors of MICA2 motes. However, the prototypes do not use the motes' transceivers. Instead, the prototypes communicate with each other using *ultra-low-power UWB-IR transceivers* [1]. Each prototype is integrated with an energy harvesting module that *collects the energy of indoor light* using *organic solar cells* designed for this project. A Fennec Fox platform is used to seamlessly integrate these hardware components [8]. To enable an interactive demo, the prototypes are placed on MIB600 programming boards which are Ethernet-connected to a computer running a graphical monitoring system.

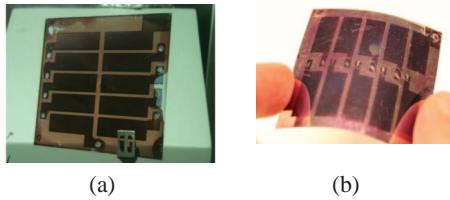

Figure 2. Custom in-house-developed organic solar cells, (a) manufactured on glass, and (b) manufactured on a flexible substrate.

In UWB-IR, the information is transmitted using short (nano-second duration) pulses [9], which enables the transceivers to sleep between pulses and allows for very low energy consumption. For example, the UWB-IR transceiver used by the current EnHANT prototypes achieves energy consumption of less than 1nJ/bit to transmit and 2-3nJ/bit to receive, which is much lower than the energy consumption of conventional narrowband wireless technologies. We implement a UWB-IR medium access control (MAC) protocol that provides addressing, reliability, and data integrity.

EnHANT prototypes include an *energy harvesting module (EHM)* that harvests and stores energy. The EHM consists of a solar cell, a rechargeable battery, and components to monitor the energy harvested by the solar cell and the battery charge state. The current prototypes use organic solar cells fabricated using Plexcore PV 2000 materials. The solar cells, shown in Fig. 2(a), were fabricated on a glass substrate. Compared to the amorphous silicon solar cells used in previous EnHANT prototypes, these new organic solar cells more efficiently harvest energy from indoor lighting, can be directly fabricated on *flexible* substrates (an example flexible solar cell is shown in Fig. 2(b)), and can be manufactured using a roll-to-roll fabrication process to reduce costs.

The ability to track energy parameters allows the prototypes to adapt their communication patterns to ambient energy. Furthermore, the communicating prototypes exchange their energy parameters and run distributed *energy-harvesting adaptive communications and networking algorithms*, jointly adapting to the overall network energy availability. We present a version of the energy-harvesting-adaptive lexicographically maximum data rate assignment algorithm introduced in [2]. We also demonstrate a set of energy-harvesting-adaptive networking algorithms that we developed in our recent work [6].

2 Demonstration

We demonstrate novel EnHANT functionalities across the layers of the protocol stack, from physical layer UWB-IR wireless communications (i.e., information exchange using short pulses) to energy-harvesting-aware networking protocols.

The demonstration setup, shown in Fig. 3, consists of four prototypes communicating with each other wirelessly using UWB-IR transceivers. An oscilloscope connected to a prototype is used to show *impulse-radio-based wireless communications*. Using an oscilloscope, demo participants can observe the individual pulses generated by the prototypes, and can visualize the details of the employed modulation and en-



Figure 3. EnHANT demonstration setup.

coding schemes.

A graphical monitoring system is used to demonstrate changes in various prototype parameters. Using a lighting installation, demo participants can vary environmental energy available to the prototypes. The prototypes exchange their energy parameters (i.e., energy harvested and energy storage levels) and adjust their communication parameters in response to changes in environmental energy. Demo participants can observe the influence of the environmental energy availability on the communications and networking behavior of the prototypes.

3 Acknowledgements

This work was supported in part by Vodafone Americas Foundation Wireless Innovation Project, United Microelectronics, a grant from Texas Instruments, and NSF grants CNS-0644202, CCF-0964497, CNS-0916263, CNS-0931870, CNS-10-54856. The UWB antennas were provided by Prof. Harish Krishnaswamy.

4 References

- [1] M. Crepaldi, C. Li, K. Dronson, J. Fernandes, and P. Kinget. An ultra-low-power interference-robust IR-UWB transceiver chipset using self-synchronizing OOK modulation. In *Proc. IEEE ISSCC'10*, Feb. 2010.
- [2] K.-W. Fan, Z. Zheng, and P. Sinha. Steady and fair rate allocation for rechargeable sensors in perpetual sensor networks. In *Proc. ACM SenSys'08*, Nov. 2008.
- [3] M. Gorlatova, P. Kinget, I. Kymissis, D. Rubenstein, X. Wang, and G. Zussman. Challenge: Ultra-low-power energy-harvesting active networked tags (EnHANTs). In *Proc. ACM MobiCom'09*, Sept. 2009.
- [4] M. Gorlatova, Z. Noorbhaiwala, A. Skolnik, J. Sarik, M. Szczodrak, J. Chen, M. Zapas, L. Carloni, P. Kinget, I. Kymissis, D. Rubenstein, and G. Zussman. Demo: Prototyping energy harvesting active networked tags. *Presented in ACM MobiCom'10*, Sept. 2010.
- [5] M. Gorlatova, T. Sharma, D. Shrestha, E. Xu, J. Chen, A. Skolnik, D. Piao, P. Kinget, I. Kymissis, D. Rubenstein, and G. Zussman. Demo: Prototyping energy harvesting active networked tags (EnHANTs) with MICA2 motes. In *Proc. IEEE SECON'10*, June 2010.
- [6] M. Gorlatova, A. Wallwater, and G. Zussman. Networking low-power energy harvesting devices: Measurements and algorithms. In *Proc. IEEE INFOCOM'11*, Apr. 2011.
- [7] A. A. Gorodetsky, M. Cox, N. J. Tremblay, I. Kymissis, and C. Nuckolls. Solar cell from a solution processable pentacene with improved air stability. *Chem. Mater.*, 21(18):4090-4092, 2009.
- [8] M. Szczodrak and L. Carloni. Demo: A complete framework for programming event-driven, self-reconfigurable low power wireless networks. In *Proc. ACM SenSys'11*, Nov. 2011.
- [9] M. Win and R. Scholtz. Ultra-wide bandwidth time-hopping spread-spectrum impulse radio for wireless multiple-access communications. *IEEE Trans. Commun.*, 48(4):679-689, Apr. 2000.
- [10] J. Zhu, G. Stanje, R. Margolies, M. Gorlatova, J. Sarik, Z. Noorbhaiwala, P. Miller, M. Szczodrak, B. Vignraham, L. Carloni, P. Kinget, I. Kymissis, and G. Zussman. Demo: Prototyping UWB-enabled EnHANTs. In *Proc. ACM MobiSys'11*, June 2011.